

Build it right
with Real Cedar

DECKS, STAIRS & RAILINGS

Design ideas for
enhancing
outdoor living

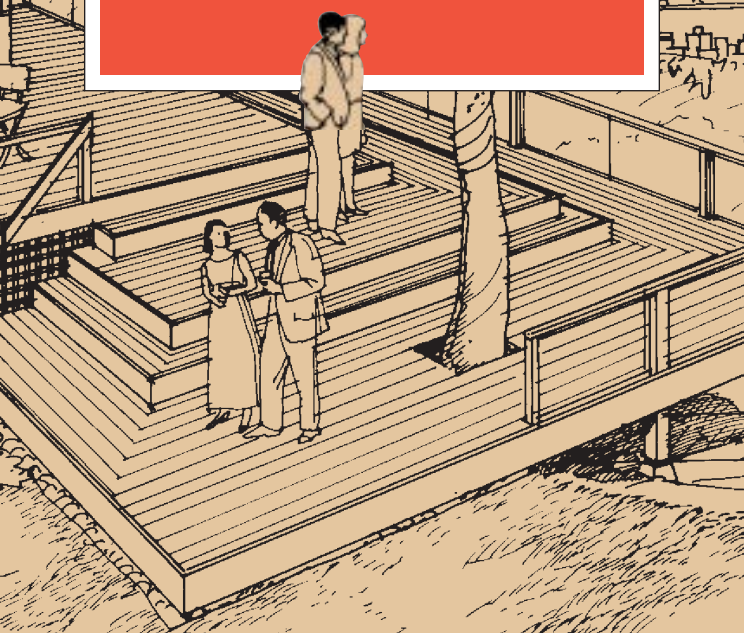

WESTERN RED CEDAR LUMBER ASSOCIATION

REAL CEDAR



REAL CEDAR FOR YOUR GREAT OUTDOORS

Decks are a satisfying and simple way to extend your home's living area outdoors – whether your space is an urban condominium, an expansive suburban estate, or something in between.

Western Red Cedar is perfectly suited for deck and outdoor stair and railing construction. Naturally decay-resistant, light in weight, easy to work, this handsome, durable wood complements any architectural style.

This brochure contains practical pointers on the construction of four architect-designed projects. We have not included step-by-step building instructions as the designs are intended simply as a source of ideas – concepts you can build on to meet your own outdoor living needs.

WESTERN RED CEDAR LUMBER ASSOCIATION

REAL CEDAR



WOOD FOR THE JOB

In adapting deck ideas to your own site, select lumber sizes appropriate for larger or smaller decks. Beam sizes for load bearing structures should be calculated using span tables available through national building codes, grading agencies and retail lumber dealers.

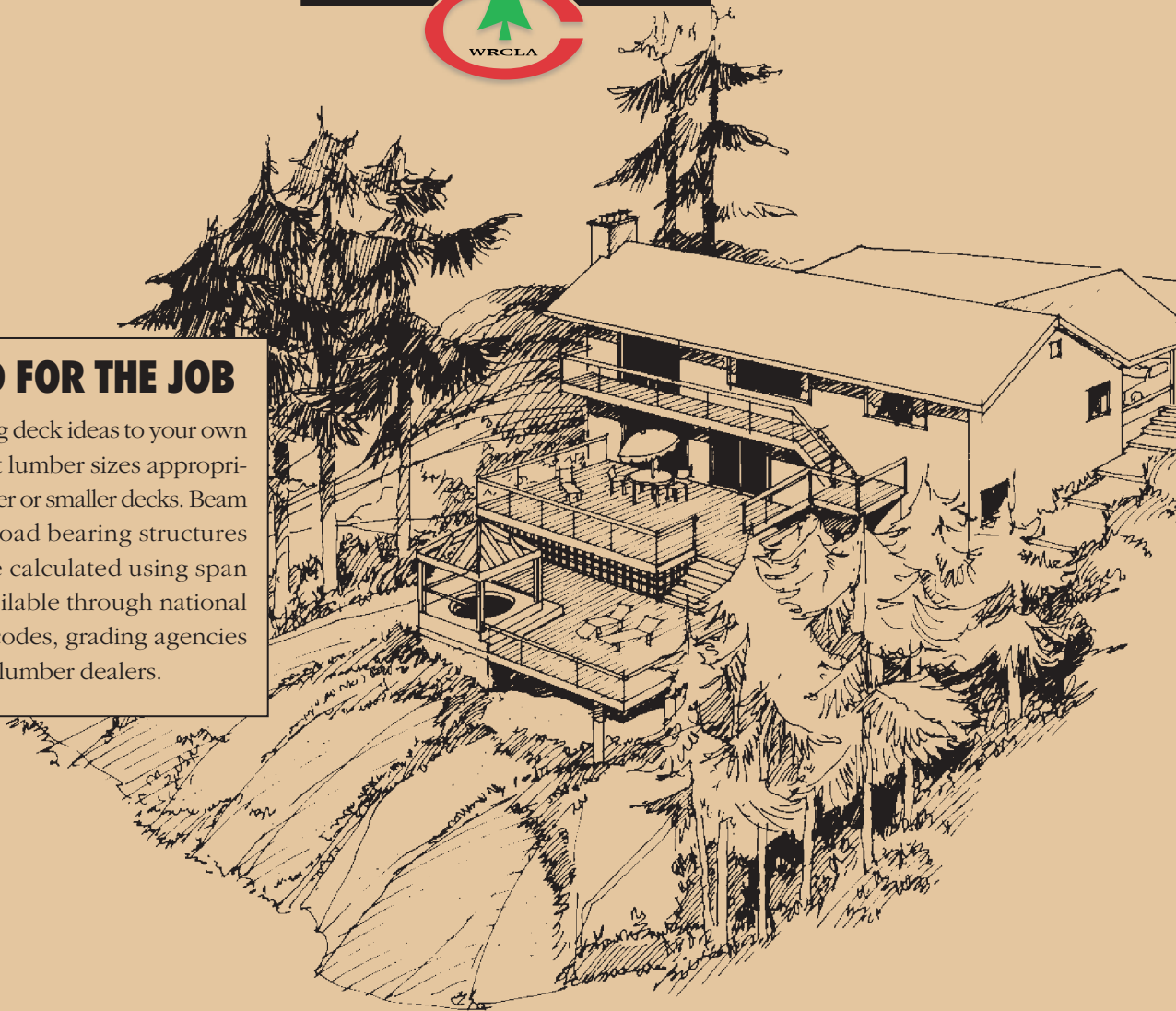

STAIRS AND RAILINGS

Most raised decks require stairs for access to ground level, while railings are necessary for safety. Along with their practical functions, stairs and railings can add architectural interest to your home and deck.

When planning stairs, consider whether you want a gradual or steep ascent and adjust ratio of riser to tread accordingly. The stair width can range all the way from the full span of a deck to a minimum 3 ft. wide.

FASTENERS & SUPPORTS

For all outdoor work you should use rust-resistant hot-dipped galvanized or stainless steel nails. Other fasteners and hardware such as bolts, screws and hinges should also be made from similar corrosion resistant materials.

FOOTINGS

Firm foundations for decks and stair posts are critical for durability and safety. Precast concrete footings are available from your building supply dealer, but pouring your own allows greater flexibility and is more likely to provide better long term performance.

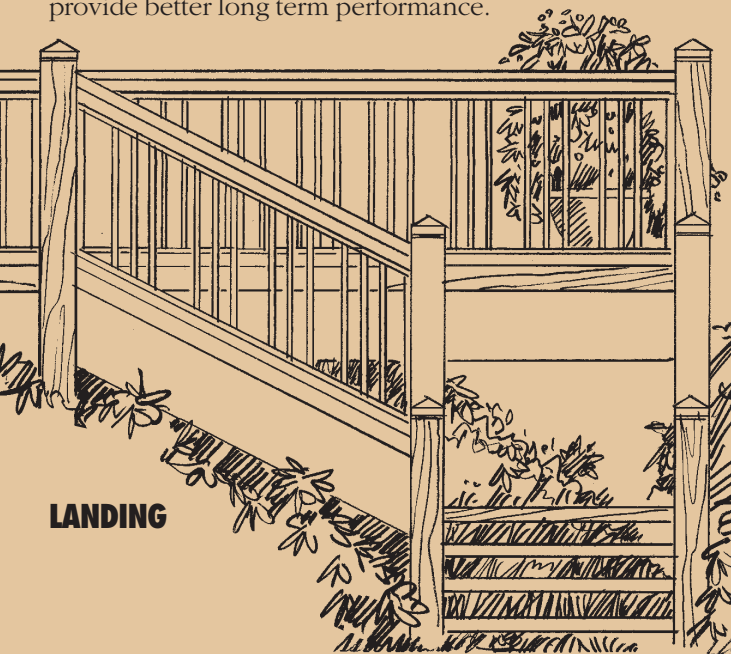

LANDING

CONSTRUCTION TIPS FOR DECKS AND STAIRS

- Measure twice, cut once.
- Use a plumb bob to check vertical line of posts.
- Drill pilot holes when nailing or screwing close to the edge of wood.
- Use a 16d nail or wood spacer to ensure equal spacing between boards.
- River rock on 6 mm poly under the deck inhibits weed growth.

Make sure that the top tread and decking are at the same level.

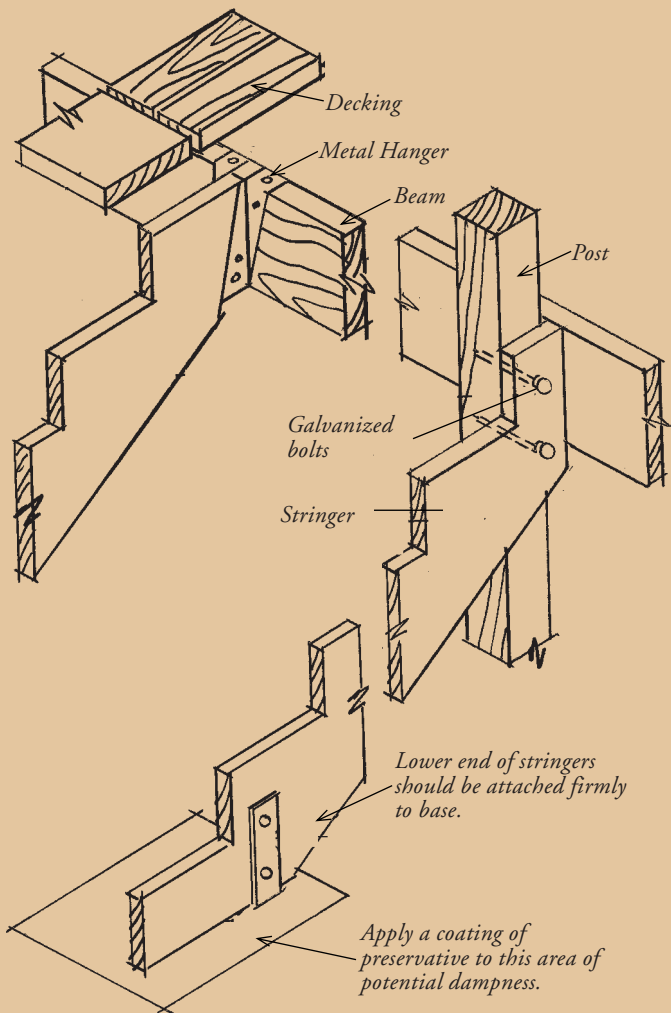

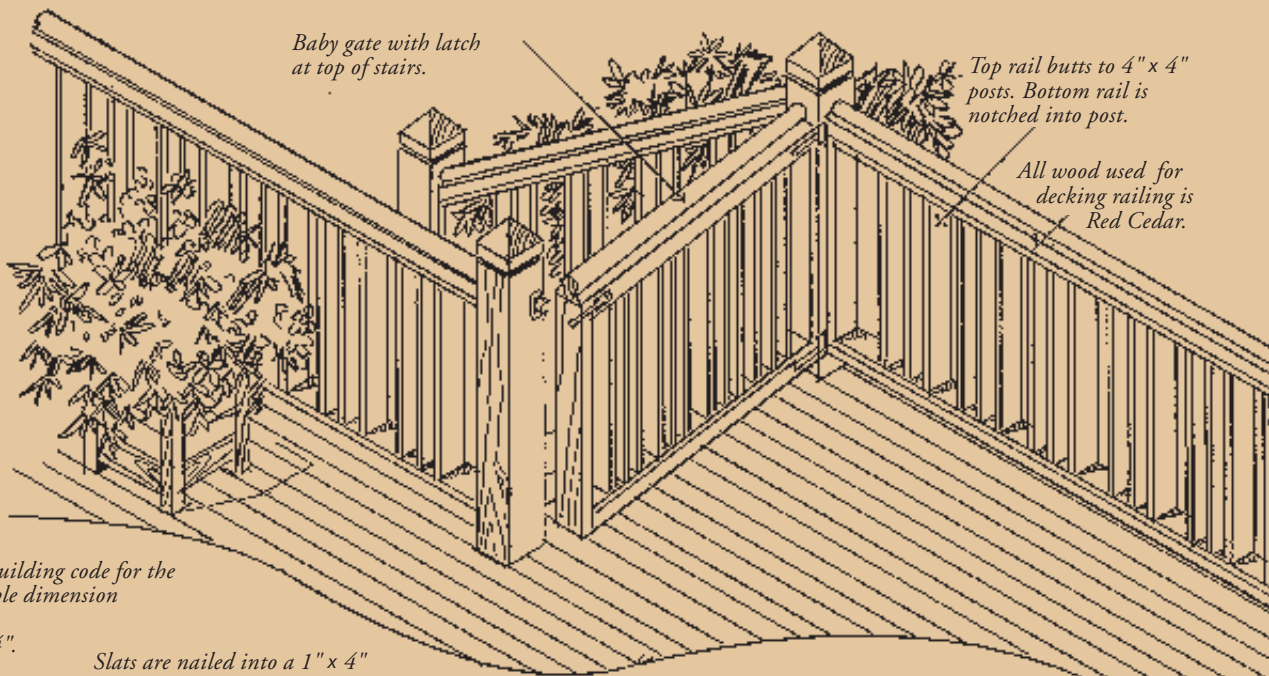

Baby gate with latch at top of stairs.

Top rail butts to 4" x 4" posts. Bottom rail is notched into post.

All wood used for decking railing is Red Cedar.

Check your local building code for the maximum allowable dimension between slats – in most cases it is 4".

Slats are nailed into a 1" x 4" frame. The frame is then set into the railing. This avoids visible nails. 1" x 4" slats are grouped in 3s, spaced at 3" O.C. Each group of 3 is spaced 4 1/2" O.C.

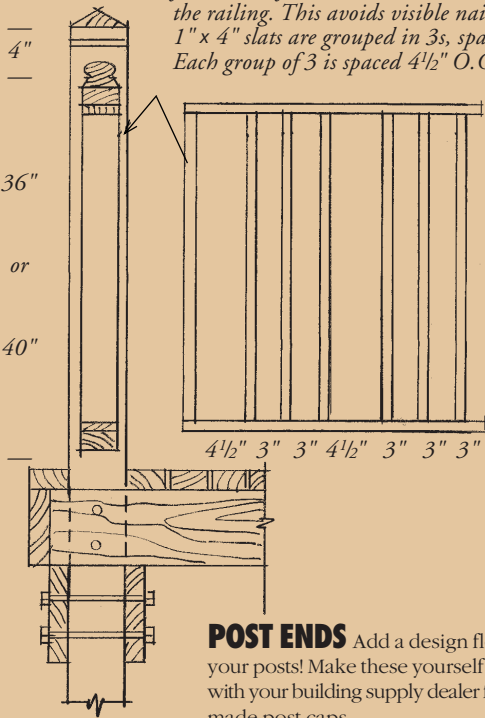

Check building codes for railing height.

POST ENDS Add a design flourish to your posts! Make these yourself or check with your building supply dealer for ready-made post caps.

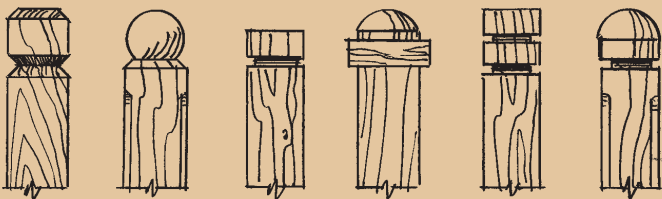

OTHER RAILING LOOKS

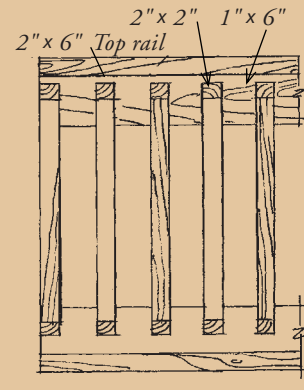
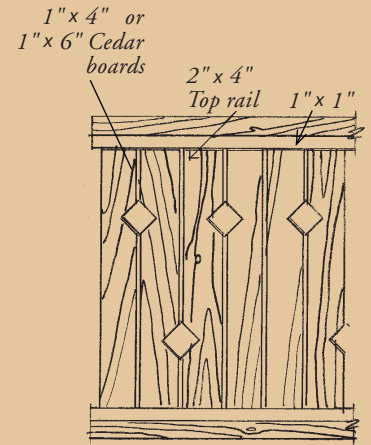
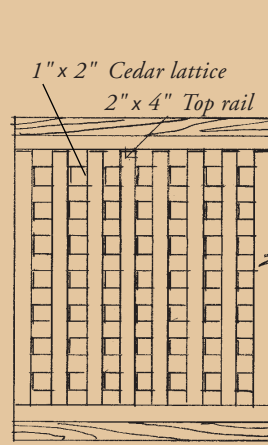

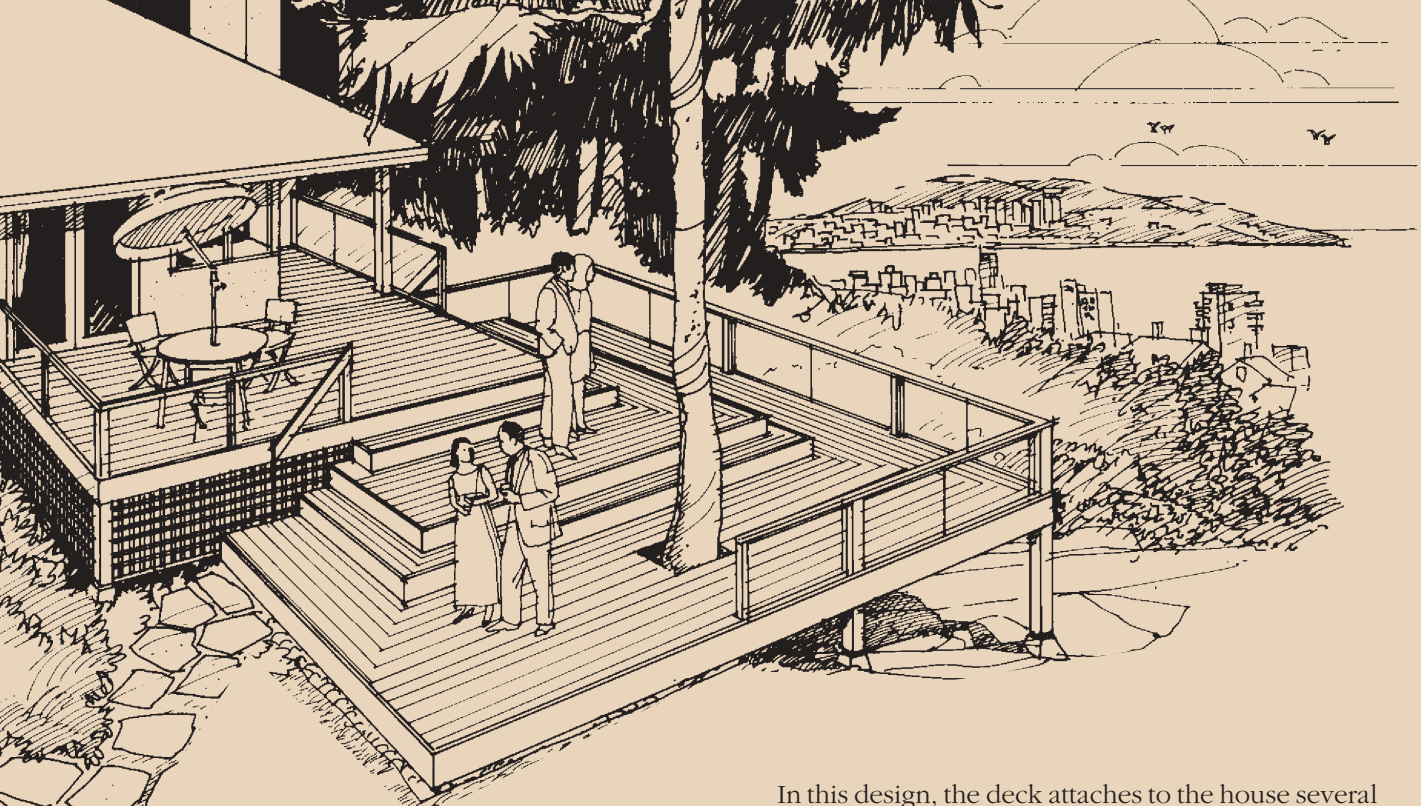

**RAISED
CEDAR
DECK**

The raised platform deck is an excellent solution to the problems created by sloping sites. This type of Cedar deck extends your livable area into previously unused space.

Terraced decks can take the best advantage of the lay of the land. They can safely traverse uneven or rocky terrain and step down from house to ground level in an interesting and easy descent.

In this design, the deck attaches to the house several feet above the ground allowing light through the basement windows. The other side extends out over the steeper area of the site to take advantage of the panoramic view.

Placing the railing on the lower level provides an unobstructed view from the upper deck. The addition of clear glass safety glass beneath the handrail permits a view from the lower deck without compromising safety.

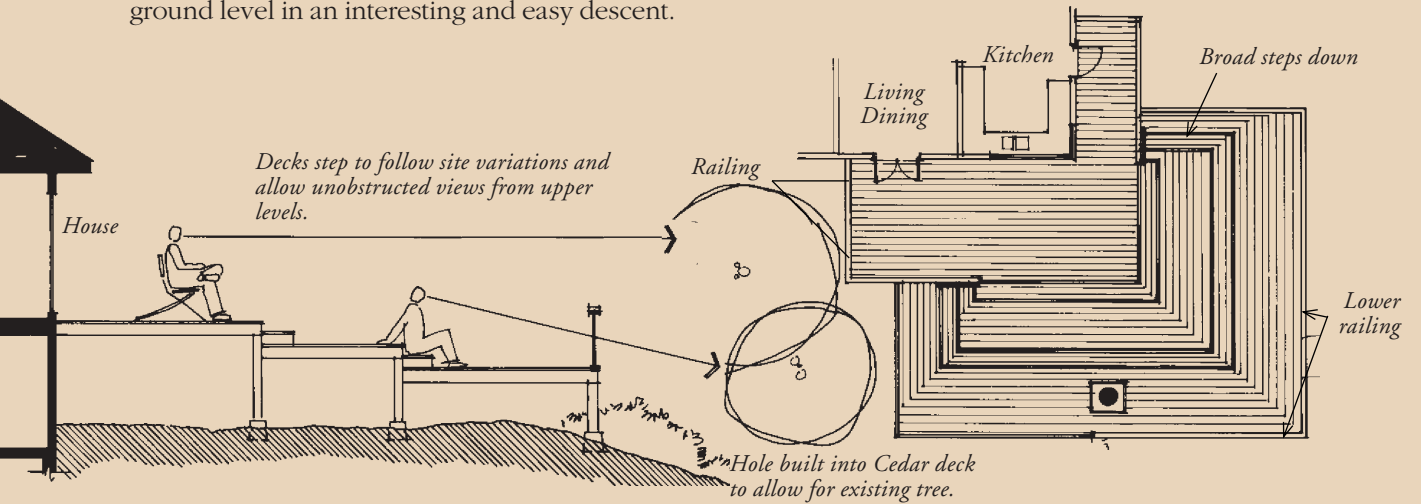

2" x 4" Cedar on flat with
1/4" space at deck.

2" x 8" Clear Cedar trim.

2 - 22" x 8" Cedar beams
on precast footings
to solid bearing.

Ledger support
bolted to wall.

2" x 8" Cedar joists
at 16" on center
on joist hangers.

the house, providing easy indoor/out-
door access for you and your guests.

Shallow pools, tubs and planters can be set into the
deck, even hot tubs or gazebos can be accommodated.

This deck is constructed of 2" x 4" Western Red Cedar
decking laid over Cedar joists. Deck edges are trimmed
with 2" x 8" Cedar.

GROUND LEVEL CEDAR DECK

The ground level deck provides
the simplest way of expanding liv-
ing space outdoors. Attached to
the house or freestanding, these
decks are particularly effective in
providing usable space over damp, rocky or rela-
tively uneven terrain. This deck is attached to

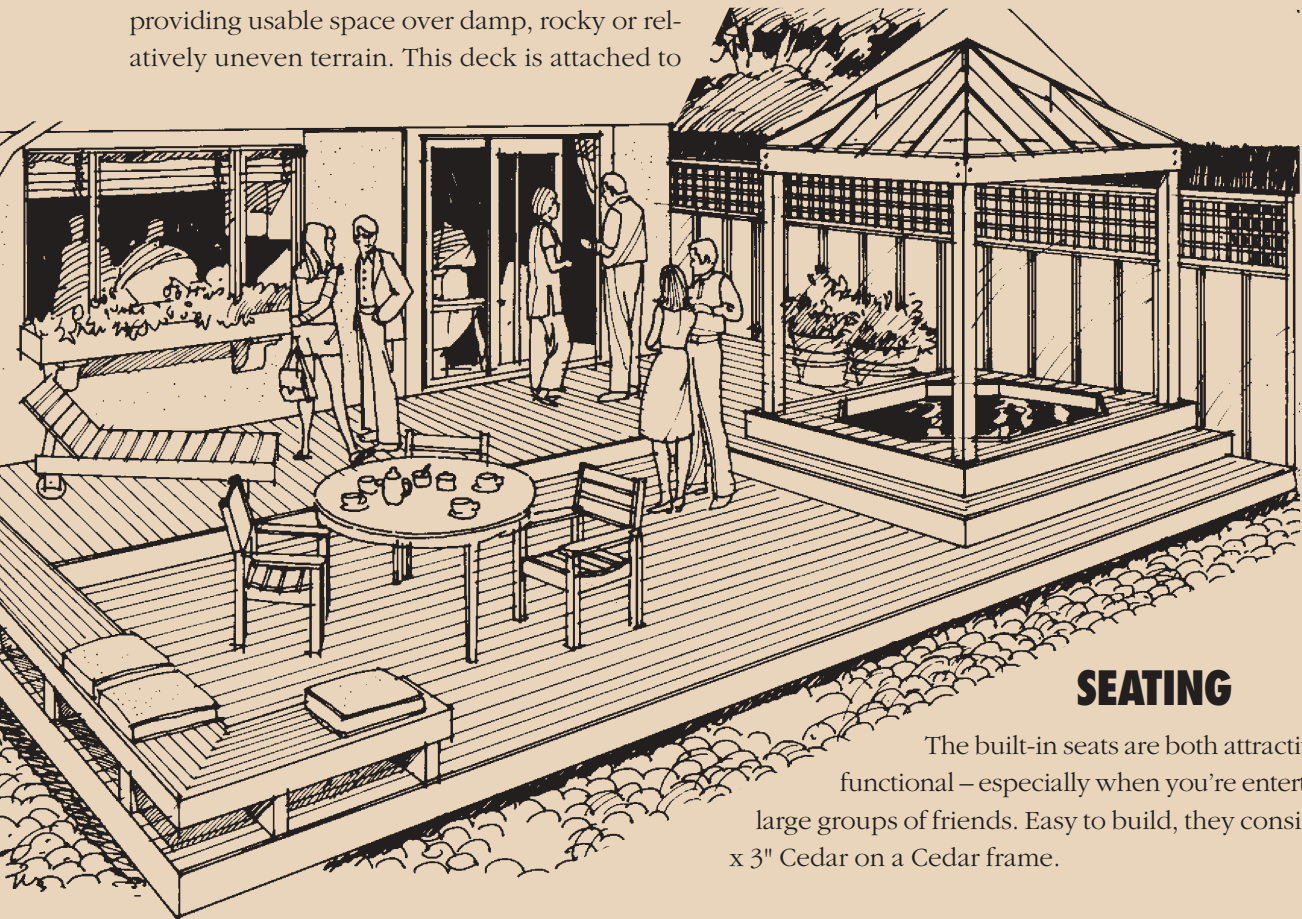

SEATING

The built-in seats are both attractive and
functional – especially when you're entertaining
large groups of friends. Easy to build, they consist of 2"
x 3" Cedar on a Cedar frame.

CEDAR ROOF DECK

When building a ground level deck is out of the question, sometimes opportunities exist above. Many buildings have the potential of developing roof space. Even very small areas can be made into attractive and practical decks.

This deck design incorporates 48" x 48" lift-out Cedar deck panels that can be laid in many interesting patterns. You can also use these deck panels to enhance ground level patios, concreted garden areas or balconies.

The 2" x 2" Cedar decking is nailed to 2" x 4" Cedar runners set on pads to protect the roofing surface below the deck. Decking is spaced with a 1/4" wood spacer, this lets the rain escape onto the roof and drain normally.

In this deck the Cedar seats are built on simple box frames that can be used for seating or displaying plants in pots. Part of the top section lifts to provide storage for tools and other items.

Angled uprights provide privacy from neighbors but do not impede views and breeze.

Hinged top for access.

Movable bench.

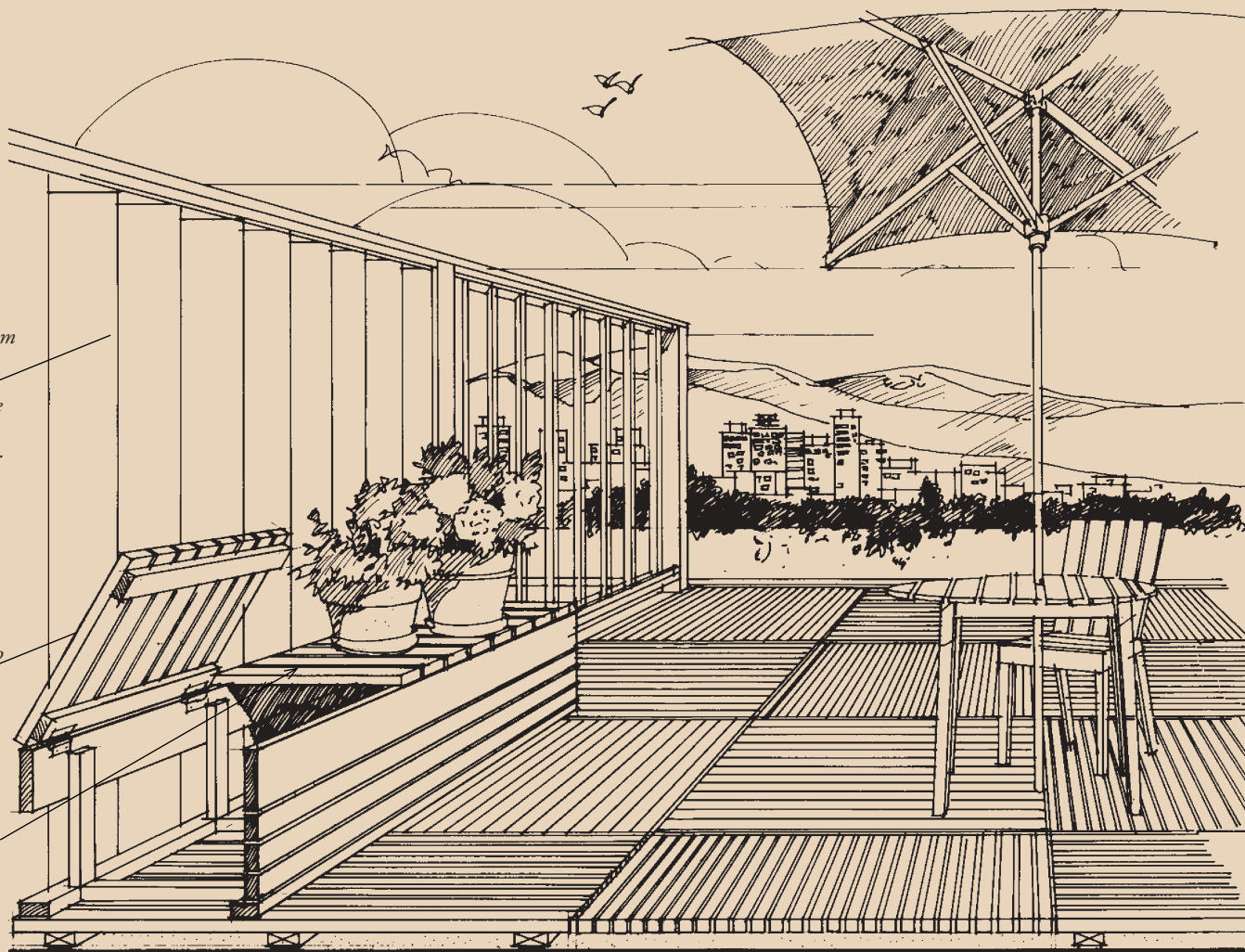

UPHILL SLOPING LOT CEDAR DECKS

On uphill sloping lots stepped Cedar decks create attractive outdoor spaces, as well as being a pleasant and easy way to access the upper levels of the property.

In the design illustrated here, landscaped areas and an outdoor games court have been incorporated into the deck plan. The Cedar lath garden house serves the family as a playhouse or alternate dining and entertaining space.

For your own site you might decide on a covered walkway to add beauty and interest to a particular garden path. Perhaps you would like a fenced-in conversation area complete with garden seats. You could also create islands of color with groupings of flower-filled planters. All these home-enhancing projects, and more, can be easily made with versatile Cedar – the natural choice for your great outdoors.

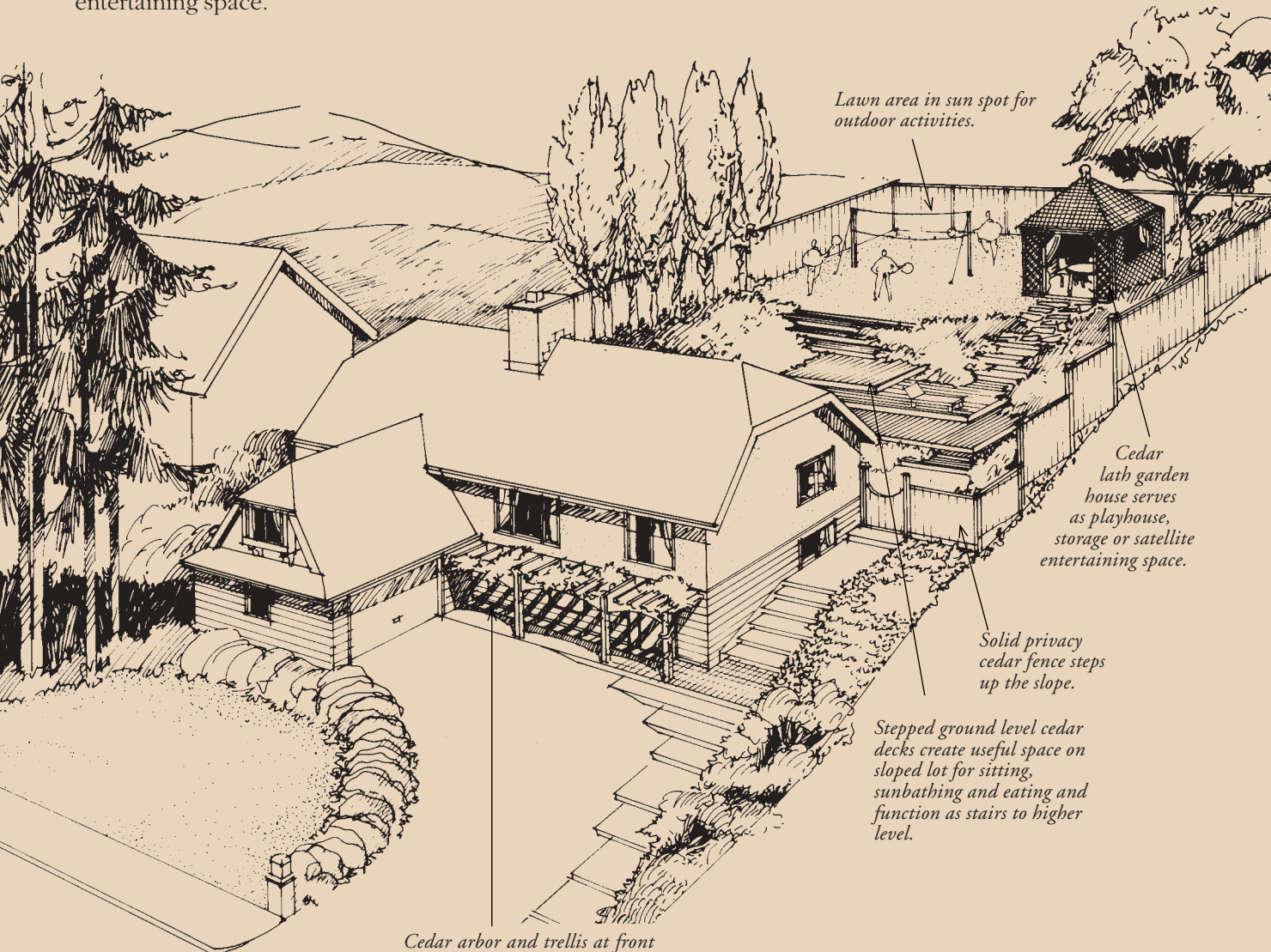

Lawn area in sun spot for outdoor activities.

Cedar lath garden house serves as playhouse, storage or satellite entertaining space.

Solid privacy cedar fence steps up the slope.

Stepped ground level cedar decks create useful space on sloped lot for sitting, sunbathing and eating and function as stairs to higher level.

Cedar arbor and trellis at front wall break down the scale and create interest as well as denote the front entry door as special.

THE FINISHING TOUCH

While Cedar can be left unfinished for a rustic weathered look, the use of a quality finish recommended by your building supply dealer can enhance both its good looks and its natural characteristics.

Red Cedar accepts a wide range of stains in your choice of tinted transparent finishes for a natural effect, or lightly pigmented semi-transparent finishes. The latter are available in a spectrum of colors.

Look for a coating that offers good fungicide and ultra-violet shielding properties as well as additional preservatives to protect your project's youthful complexion. Varnishes and other film-forming coatings which can crack and peel are not recommended for use on Cedar.

CHECK OUT ALL OUR "BUILD IT RIGHT WITH REAL CEDAR" BROCHURES:

- Decks, Stairs & Railings
- Gazebos & Outbuildings
- Fences & Gates
- Planter Boxes, Benches & Tables
- Arbors, Trellises & Pergolas

REAL CEDAR OFFERS YOU EXTRA ASSURANCE:

The Western Red Cedar Lumber Association mark of quality tells you it's Real Cedar, carefully manufactured and strictly graded for your intended use.

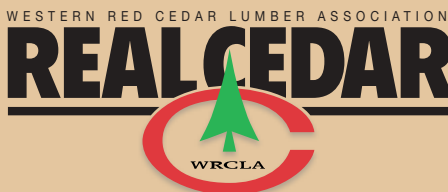

Vancouver, BC Canada

Toll Free: 1-866-778-9096

Email: info@wrcla.org www.realcedar.org